



GF001H

Green-Mode Fairchild Power Switch (FPS™)

Features

- Advanced Burst Mode Operation at No-Load Condition
- 700 V High-Voltage JFET Startup Circuit
- Internal Avalanche-Rugged 700 V SenseFET
- Built-in 5 ms Soft-Start
- Peak-Current-Mode Control
- Cycle-by-Cycle Current Limiting
- Leading-Edge Blanking (LEB)
- Synchronized Slope Compensation
- Frequency Modulation to Attenuating EMI
- Internal Overload / Open-Loop Protection (OLP)
- V_{DD} Under-Voltage Lockout (UVLO)
- V_{DD} Over-Voltage Protection (OVP)
- Internal Auto-Restart Circuit (OLP, V_{DD} OVP)
- Adjustable Peak Current Limit

Description

The GF001H is a next-generation, Green-Mode Fairchild Power Switch (FPS™). It integrates an advanced current-mode Pulse Width Modulator (PWM) and an avalanche-rugged 700 V SenseFET in a single package, allowing auxiliary power designs with higher standby energy efficiency, reduced size, improved reliability, and lower system cost than previous solutions.

A new frequency modulation reduces EMI emission and built-in synchronized slope compensation allows stable peak-current-mode control over a wide range of input voltage.

Requiring a minimum number of external components, the GF001H provides a solid platform for cost-effective flyback converter design with low standby power consumption.

Ordering Information

Part Number	SenseFET	Operating Temperature Range	Package	Packing Method
GF001HN	2 A 700 V	-40°C to +105°C	8-Pin, Dual Inline Package (DIP)	Tube

Application Diagram

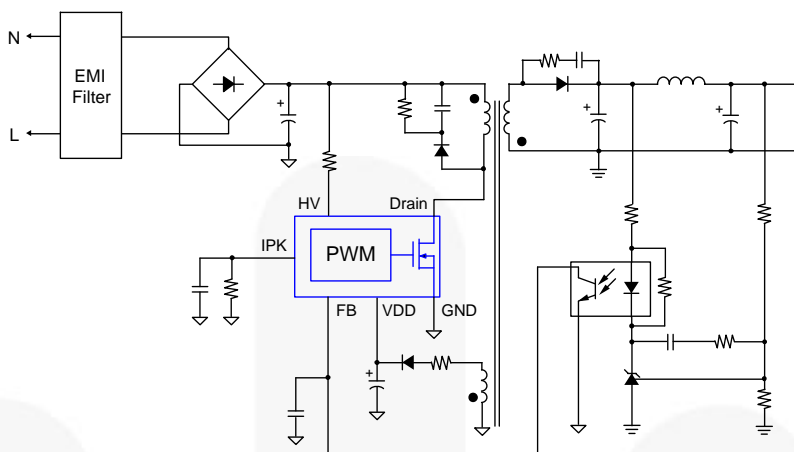

Figure 1. Typical Flyback Application

Output Power Table ⁽¹⁾

Product	230 V _{AC} ±15% ⁽²⁾		85-265 V _{AC}	
	Adapter ⁽³⁾	Open-Frame ⁽⁴⁾	Adapter ⁽³⁾	Open-Frame ⁽⁴⁾
GF001HN	14 W	20 W	11 W	16 W

Notes:

1. The maximum output power can be limited by junction temperature.
2. 230 V_{AC} or 100/115 V_{AC} with voltage doublers.
3. Typical continuous power in a non-ventilated enclosed adapter, with sufficient drain pattern of printed circuit board (PCB) as a heat sink, at 50°C ambient.
4. Maximum practical continuous power in an open-frame, design with sufficient drain pattern of printed circuit board (PCB) as a heat sink, at 50°C ambient.

Block Diagram

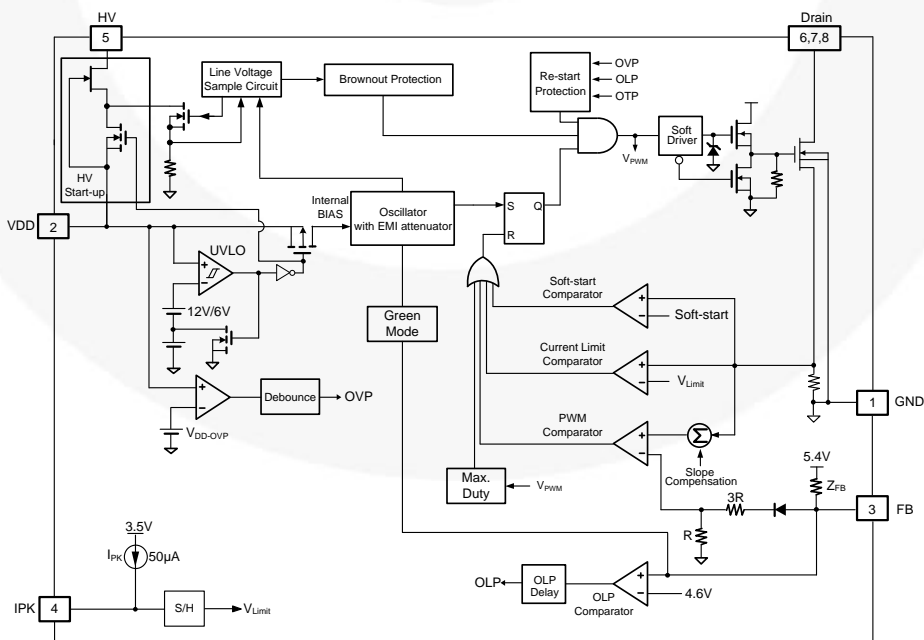
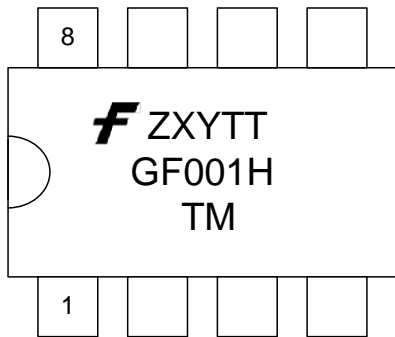

Figure 2. Internal Block Diagram

Marking Information



- F – Fairchild Logo
- Z – Plant Code
- X – 1-Digit Year Code
- Y – 1-Digit Week Code
- TT – 2-Digit Die Run Code
- T – Package Type (N: DIP)
- M – Manufacture Flow Code

Figure 3. Top Mark

Pin Configuration

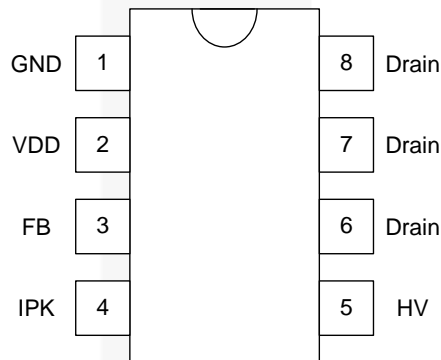

Figure 4. Pin Assignment

Pin Definitions

Pin #	Name	Description
1	GND	Ground. This pin internally connects to the SenseFET source and signal ground of the PWM controller.
2	VDD	Supply Voltage of the IC. Typically the hold-up capacitor connects from this pin to ground. A rectifier diode in series with the transformer auxiliary winding connects to this pin to supply bias during normal operation.
3	FB	Feedback. The signal from the external compensation circuit connects to this pin. The PWM duty cycle is determined by comparing the signal on this pin and the internal current-sense signal.
4	IPK	Adjust Peak Current. Typically a resistor connects from this pin to the GND pin to program the current-limit level. The internal current source (50 μ A) introduces voltage drop across the resistor, which determines the current-limit level of pulse-by-pulse current limit.
5	HV	Startup. Typically, resistors in series from DC line connect to this pin to supply internal bias and to charge the external capacitor connected between the VDD pin and the GND pin during startup. This pin is also used to sense the line voltage for brownout protection.
6	Drain	SenseFET Drain. This pin is designed to directly drive the transformer.
7		
8		

Absolute Maximum Ratings

Stresses exceeding the absolute maximum ratings may damage the device. The device may not function or be operable above the recommended operating conditions and stressing the parts to these levels is not recommended. In addition, extended exposure to stresses above the recommended operating conditions may affect device reliability. The absolute maximum ratings are stress ratings only.

Symbol	Parameter	Min.	Max.	Unit
V_{DRAIN}	Drain Pin Voltage ^(5,6)		700	V
I_{DM}	Drain Current Pulsed ⁽⁷⁾		8.0	A
E_{AS}	Single Pulsed Avalanche Energy ⁽⁸⁾		140	mJ
V_{DD}	DC Supply Voltage		25	V
V_{FB}	FB Pin Input Voltage	-0.3	6.0	V
V_{IPK}	IPK Pin Input Voltage	-0.3	6.0	V
V_{HV}	HV Pin Input Voltage		700	V
P_D	Power Dissipation ($T_A < 50^\circ\text{C}$)		1.5	W
T_J	Operating Junction Temperature	-40	Internally Limited ⁽⁹⁾	$^\circ\text{C}$
T_{STG}	Storage Temperature Range	-55	+150	$^\circ\text{C}$
T_L	Lead Soldering Temperature (Wave Soldering or IR, 10 Seconds)		+260	$^\circ\text{C}$

Notes:

- All voltage values, except differential voltages, are given with respect to the network ground terminal.
- Stresses beyond those listed under Absolute Maximum Ratings may cause permanent damage to the device.
- Non-repetitive rating: pulse width is limited by the maximum junction temperature.
- $L = 51 \text{ mH}$, starting $T_J = 25^\circ\text{C}$.
- Internally limited by Over-Temperature Protection(OTP). Refer to T_{OTP} .

Thermal Resistance Table

Symbol	Parameter	Value	Unit
θ_{JA}	Junction-to-Air Thermal Resistance	86	$^\circ\text{C/W}$
ψ_{JT}	Junction-to-Package Thermal Resistance ⁽¹⁰⁾	20	$^\circ\text{C/W}$

Note:

- Measured on the package top surface.

ESD Capability

Symbol	Parameter	Value	Unit
ESD	Human Body Model, JESD22-A114 ⁽¹¹⁾	All pins excluding HV pin	7
		All pins including HV pin	3
	Charged Device Model, JESD22-C101 ⁽¹¹⁾	All pins excluding HV pin	2
		All pins including HV pin	2

Note:

- Meets JEDEC standards JESD 22-A114 and JESD 22-C101.

Electrical Characteristics

$V_{DD}=15\text{ V}$, and $T_A=25^\circ\text{C}$ unless otherwise specified.

Symbol	Parameter	Condition	Min.	Typ.	Max.	Unit
SenseFET Section⁽¹²⁾						
BV_{DSS}	Drain-Source Breakdown Voltage	$V_{DS} = 700\text{ V}$, $V_{GS} = 0\text{ V}$	700			V
I_{DSS}	Zero-Gate-Voltage Drain Current	$V_{DS} = 700\text{ V}$, $V_{GS} = 0\text{ V}$			50	μA
		$V_{DS} = 560\text{ V}$, $V_{GS} = 0\text{ V}$, $T_C = 125^\circ\text{C}$			200	
$R_{DS(ON)}$	Drain-Source On-State Resistance ⁽¹²⁾	$V_{GS} = 10\text{ V}$, $I_D = 0.5\text{ A}$		6.0	7.2	Ω
C_{ISS}	Input Capacitance	$V_{GS} = 0\text{ V}$, $V_{DS} = 25\text{ V}$, $f = 1\text{ MHz}$		550	715	pF
C_{OSS}	Output Capacitance	$V_{GS} = 0\text{ V}$, $V_{DS} = 25\text{ V}$, $f = 1\text{ MHz}$		38	50	pF
C_{RSS}	Reverse Transfer Capacitance	$V_{GS} = 0\text{ V}$, $V_{DS} = 25\text{ V}$, $f = 1\text{ MHz}$		17	26	pF
$t_{d(on)}$	Turn-On Delay	$V_{DS} = 350\text{ V}$, $I_D = 1.0\text{ A}$		20	50	ns
t_r	Rise Time	$V_{DS} = 350\text{ V}$, $I_D = 1.0\text{ A}$		15	40	ns
$t_{d(off)}$	Turn-Off Delay	$V_{DS} = 350\text{ V}$, $I_D = 1.0\text{ A}$		55	120	ns
t_f	Fall Time	$V_{DS} = 350\text{ V}$, $I_D = 1.0\text{ A}$		25	60	ns
Control Section						
VDD Section						
V_{DD-ON}	UVLO Start Threshold Voltage		11	12	13	V
$V_{DD-OFF1}$	UVLO Stop Threshold Voltage		5	6	7	V
$V_{DD-OFF2}$	I_{DD-OLP} Enable Threshold Voltage		8	9	10	V
V_{DD-OLP}	V_{DD} Voltage Threshold for HV Startup Turn-On at Protection Mode		5	6	7	V
I_{DD-ST}	Startup Supply Current	$V_{DD-ON} - 0.16\text{ V}$			30	μA
I_{DD-OP1}	Operating Supply Current with Normal Switching Operation	$V_{DD}=15\text{ V}$, $V_{FB}=3\text{ V}$			3.8	mA
I_{DD-OP2}	Operating Supply Current without Switching Operation	$V_{DD}=15\text{ V}$, $V_{FB}=1\text{ V}$			1.8	mA
I_{DD-OLP}	Internal Sinking Current	$V_{DD-OLP} + 0.1\text{ V}$	30	60	90	μA
V_{DD-OVP}	V_{DD} Over-Voltage Protection		23	24	25	V
$t_{D-VDDOVP}$	V_{DD} Over-Voltage Protection Debounce Time		40	105	170	μs
HV Section						
I_{HV}	Supply Current Drawn from HV Pin	$HV=120\text{ V}_{DC}$, $V_{DD}=0\text{ V}$ with $10\text{ }\mu\text{F}$	1.5		5.0	mA
V_{HV}	Minimum HV Voltage for V_{DD} being charged to V_{DD-ON}	$R_{HV}=0\text{ }\Omega$, $T_A=-40^\circ\text{C}$ to 105°C	30			V
I_{HV-LC}	Leakage Current after Startup	$HV=700\text{ V}$, $V_{DD}=V_{DD-OFF1}+1\text{ V}$			10	μA
V_{DC-ON}	Brown-in Threshold Level (V_{DC})	DC Voltage Applied to HV Pin Through $200\text{ k}\Omega$ Resistor	104	114	124	V
V_{DC-OFF}	Brownout Threshold Level (V_{DC})		89	99	109	V
t_{UVP}	Brownout Protection Time		0.8	1.2	1.6	s

Continued on the following page...

Electrical Characteristics (Continued)V_{DD}=15 V, T_A=25°C unless otherwise specified.

Symbol	Parameter	Condition	Min.	Typ.	Max.	Unit
Oscillator Section						
f _{OSC}	Frequency in Nominal Mode	Center Frequency	94	100	106	kHz
f _M	Frequency Modulation			±6		kHz
f _{OSC-G}	Green-Mode Frequency		20	23	26	kHz
f _{DV}	Frequency Variation vs. V _{DD} Deviation	V _{DD} =11 V to 22 V			5	%
f _{DT}	Frequency Variation vs. Temperature Deviation ⁽¹²⁾	T _A =-40 °C to 105 °C			5	%
Feedback Input Section						
A _V	Internal Voltage Dividing Factor of FB Pin ⁽¹²⁾		1/4.5	1/4.0	1/3.5	V/V
Z _{FB}	Pull-Up Impedance of FB Pin		15	21	27	kΩ
V _{FB-OPEN}	FB Pin Pull-Up Voltage	FB Pin Open	5.2	5.4	5.6	V
V _{FB-OLP}	FB Voltage Threshold to Trigger Open-Loop Protection		4.3	4.6	4.9	V
t _{D-OLP}	Delay of FB Pin Open-Loop Protection		46	56	66	ms
V _{FB-N}	FB Voltage Threshold to Exit Green Mode	V _{FB} is Rising	2.4	2.6	2.8	V
V _{FB-G}	FB Voltage Threshold to Enter Green Mode	V _{FB} is Falling		V _{FB-N} -0.2		V
V _{FB-ZDC}	FB Voltage Threshold to Enter Zero-Duty State	V _{FB} is Falling	1.1	1.2	1.3	V
V _{FB-ZDCR}	FB Voltage Threshold to Exit Zero-Duty State	V _{FB} is Rising		V _{FB-ZDC} +0.1		V
IPK Pin Section						
V _{IPK-OPEN}	IPK Pin Open Voltage		3.0	3.5	4.0	V
V _{IPK-H}	Internal Upper Clamping Voltage of IPK Pin ⁽¹²⁾				3	V
V _{IPK-L}	Internal Lower Clamping Voltage of IPK Pin ⁽¹²⁾		1.5			V
I _{PK}	Internal Current Source of IPK Pin	T _A =-40 °C to 105 °C, V _{IPK} =2.25 V	45	50	55	μA
I _{LMT-H}	Flat Threshold Level of Current Limit for the Highest IPK Level	V _{IPK} =3 V	0.90	1.00	1.10	A
I _{LMT-L}	Flat Threshold Level of Current Limit for the Lowest IPK Level	V _{IPK} =1.5 V	0.45	0.50	0.55	A
Current-Sense Section⁽¹³⁾						
t _{PD}	Current Limit Turn-Off Delay ⁽¹⁴⁾			100	200	ns
t _{LEB}	Leading-Edge Blanking Time ⁽¹⁴⁾		160	210	260	ns
t _{SS}	Soft-Start Time ⁽¹²⁾			5		ms
GATE Section⁽¹³⁾						
DCY _{MAX}	Maximum Duty Cycle		70			%
Over Temperature Protection Section (OTP)						
T _{OTP}	Junction Temperature to Trigger OTP ⁽¹²⁾		140			°C

Notes:

12. Guaranteed by design; not 100% tested in production.
13. Pulse test: pulse width ≤ 300 μs, duty ≤ 2%.
14. These parameters, although guaranteed, are tested in wafer-sort process.

Typical Characteristics

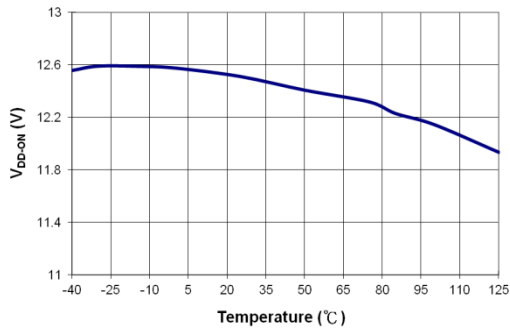

Figure 5. V_{DD-ON} vs. Temperature

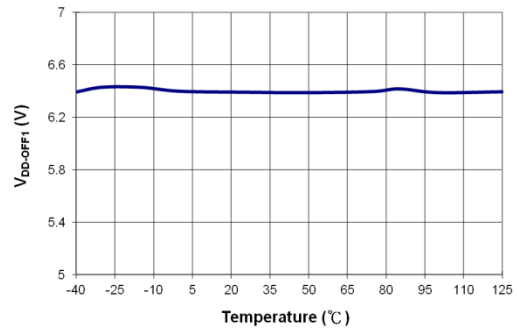

Figure 6. V_{DD-OFF1} vs. Temperature

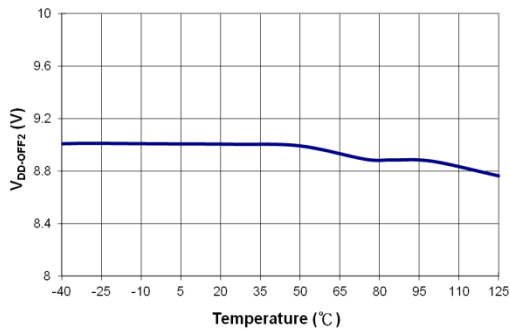

Figure 7. V_{DD-OFF2} vs. Temperature

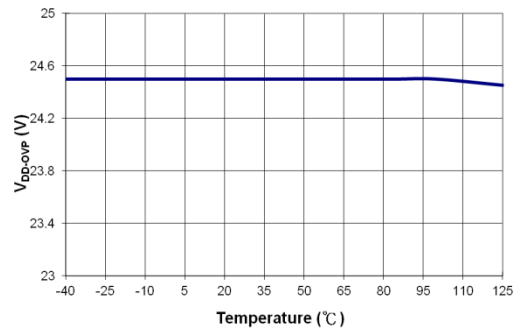

Figure 8. V_{DD-OVP} vs. Temperature

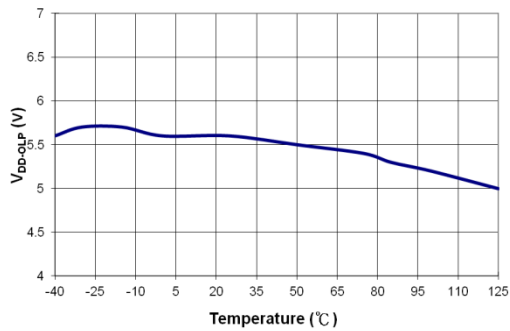

Figure 9. V_{DD-OLP} vs. Temperature

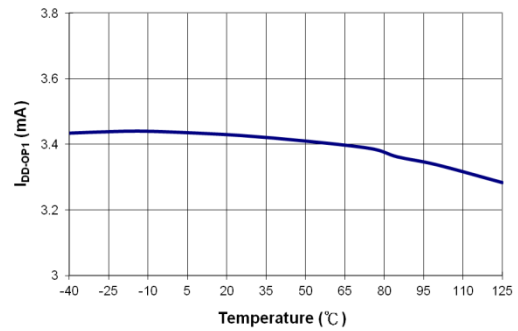

Figure 10. I_{DD-OP1} vs. Temperature

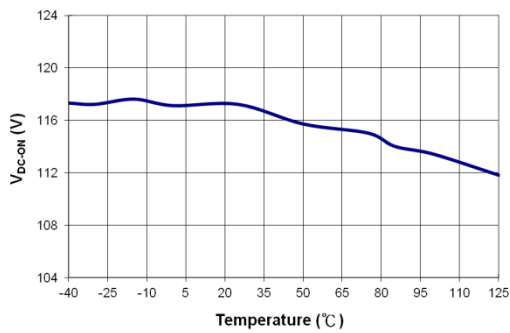

Figure 11. V_{DC-ON} vs. Temperature

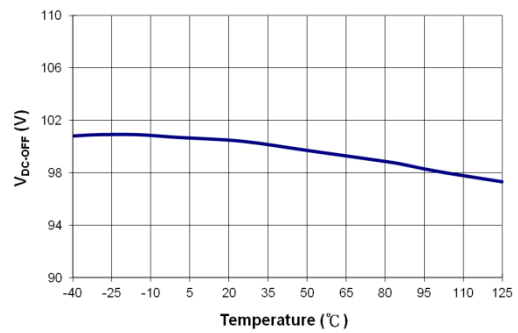

Figure 12. V_{DC-OFF} vs. Temperature

Typical Characteristics (Continued)

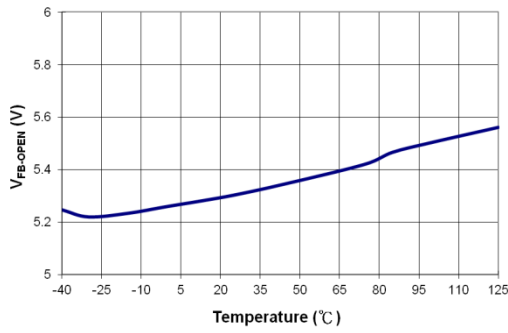

Figure 13. V_{FB-OPEN} vs. Temperature

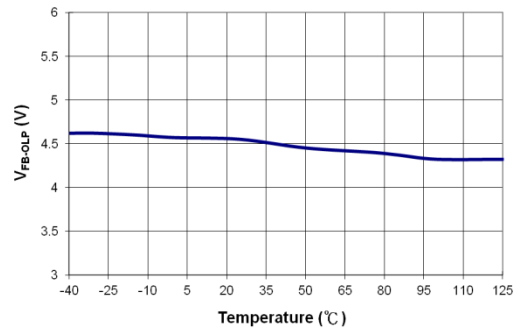

Figure 14. V_{FB-OLP} vs. Temperature

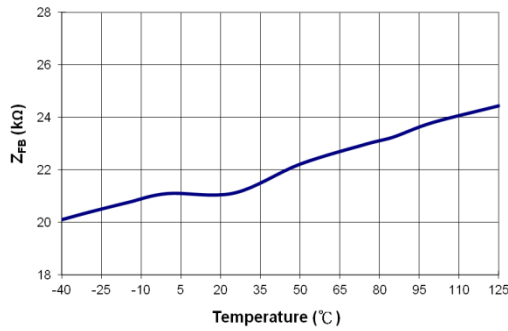

Figure 15. Z_{FB} vs. Temperature

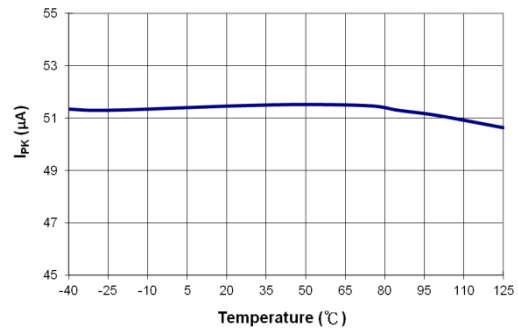

Figure 16. I_{PK} vs. Temperature

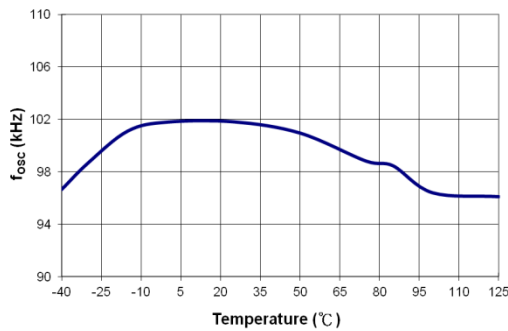

Figure 17. f_{OSC} vs. Temperature

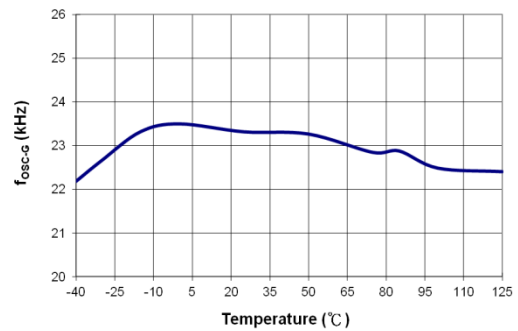

Figure 18. f_{OSC-G} vs. Temperature

Functional Description

Startup Operation

The HV pin is typically connected to the DC link input through one resistor (R_{HV}), as shown in Figure 19. When the DC input voltage is applied, the V_{DD} hold-up capacitor is charged by the line voltage through the resistor. After V_{DD} voltage reaches the turn-on threshold voltage (V_{DD-ON}), the startup circuit charging the V_{DD} capacitor is switched off and V_{DD} is supplied by the auxiliary winding of the transformer. Once the GF001H starts, it continues operation until V_{DD} drops below 6 V ($V_{DD-OFF1}$). The IC startup time with a given DC input voltage is:

$$t_{STARTUP} = R_{HV} \cdot C_{DD} \cdot \ln \frac{V_{DC}}{V_{DC} - V_{DD-ON}} \quad (1)$$

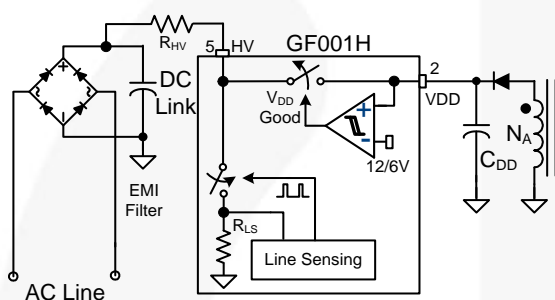

Figure 19. Startup Circuit

Brown-in/out Function

The HV pin can detect the DC link voltage using a switched voltage divider that consists of external resistor (R_{HV}) and internal resistor (R_{LS}), as shown in Figure 19. The internal DC input voltage sensing circuit detects the input voltage using a sampling circuit and peak-detection circuit. Since the voltage divider causes power consumption when it is switched on, the switching is driven by a signal with a very narrow pulse width to minimize power loss. The sampling frequency is adaptively changed according to the load condition to minimize power consumption in light-load condition.

Based on the detected DC input voltage, brown-in and brownout thresholds are determined. Since the internal resistor (R_{LS}) of the voltage divider is much smaller than R_{HV} , the thresholds are given:

$$V_{BROWN-IN} = \frac{R_{HV}}{200k} \cdot V_{DC-ON} \quad (2)$$

$$V_{BROWNOUT} = \frac{R_{HV}}{200k} \cdot V_{DC-OFF} \quad (3)$$

PWM Control

The GF001H employs current-mode control, as shown in Figure 20. An opto-coupler (such as the H11A817A) and shunt regulator (such as the KA431) are typically used to implement the feedback network. Comparing the feedback voltage with the voltage across the R_{sense} resistor makes it possible to control the switching duty cycle. A synchronized positive slope is added to the SenseFET current information to guarantee stable current-mode control over a wide range of input voltage. The built-in slope compensation stabilizes the current loop and prevents sub-harmonic oscillation.

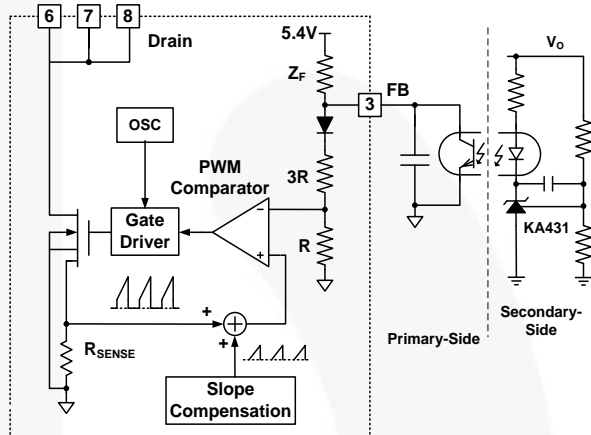

Figure 20. Current Mode Control

Soft-Start

The GF001H has an internal soft-start circuit that progressively increases the pulse-by-pulse current limit level of MOSFET during startup to establish the correct working conditions for transformers and capacitors, as shown in Figure 21. The current limit levels have nine steps, as shown in Figure 22. This prevents transformer saturation and reduces stress on the secondary diode during startup.

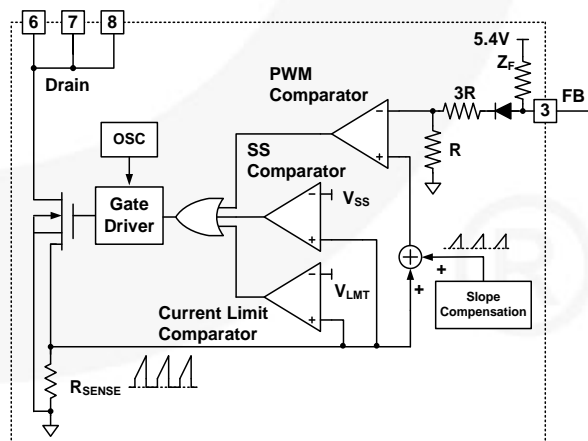

Figure 21. Soft-Start and Current-Limit Circuit

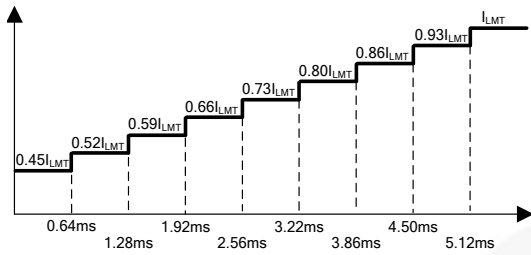

Figure 22. Current Limit Variation During Soft-Start
Adjustable Peak Current Limit

The peak current limit is programmable using a resistor on the IPK pin. The internal current 50 μ A source for the IPK pin generates voltage drop across the resistor. The voltage of the IPK pin determines the current-limit level. Since the upper and lower clamping voltage of the IPK pin are 3 V and 1.5 V, respectively; the suggested resistor value is from 30 k Ω to 60 k Ω .

Green Mode

As output load condition is reduced, the switching loss becomes the largest power loss factor. GF001H uses the FB pin voltage to monitor output load condition. As output load decreases, V_{FB} decreases and switching frequency declines, show in Figure 23. Once V_{FB} falls to 2.4 V, the switching frequency varies between 21.5 kHz and 24.5 kHz before Burst Mode operation. At Burst Mode operation, random frequency fluctuation still functions.

As V_{FB} falls below V_{FB-ZDC} , the GF001H enters Burst Mode, where PWM switching is disabled. The output voltage starts to drop, causing the feedback voltage to rise. Once V_{FB} rises above $V_{FB-ZDCR}$, switching resumes. Burst Mode alternately enables and disables switching, thereby reducing switching loss to reduce power consumption, shown in Figure 24.

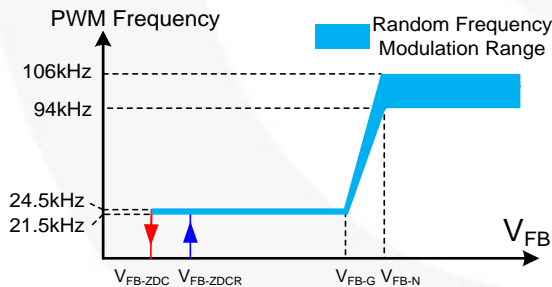

Figure 23. PWM Frequency

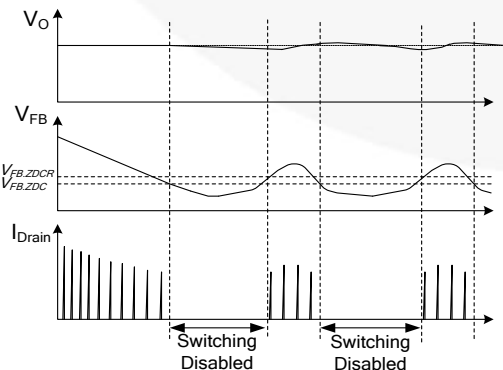

Figure 24. Burst-Mode Operation

Protections

The GF001H provides protection functions that include Overload / Open-Loop Protection (OLP) and Over-Voltage Protection (OVP). All the protections are implemented as Auto-Restart Mode. Once the fault condition is detected, switching is terminated and the SenseFET remains off, this causes V_{DD} to fall. When V_{DD} falls to 6 V, the protection is reset and HV startup circuit charges V_{DD} up to 12 V voltage, allowing restart.

Open-Loop / Overload Protection (OLP)

Because of the pulse-by-pulse current-limit capability, the maximum peak current through the SenseFET is limited and maximum input power is limited. If the output consumes more than the limited maximum power, the output voltage (V_O) drops below the set voltage. The current through the opto-coupler LED and the transistor become virtually zero and FB voltage is pulled HIGH, shown in Figure 25. If feedback voltage is above 4.6 V for longer than 56 ms, OLP is triggered. This protection is also triggered when the feedback loop is open due to a soldering defect.

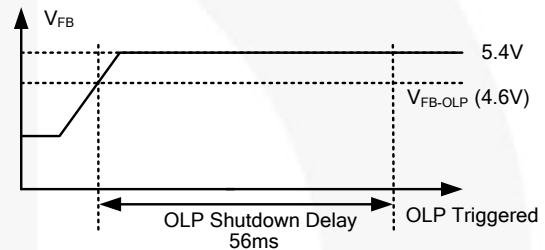

Figure 25. OLP Operation

V_{DD} Over-Voltage Protection (OVP)

If the secondary-side feedback circuit malfunctions or a solder defect causes an opening in the feedback path, the current through the opto-coupler transistor becomes virtually zero. Feedback voltage climbs in a similar manner to the overload situation, forcing the preset maximum current to be supplied to the SMPS until the overload protection triggers. Since more energy than required is provided to the output, the output voltage may exceed the rated voltage before the overload protection triggers, resulting in the breakdown of the devices in the secondary side. To prevent this situation, an OVP circuit is employed. Since V_{DD} voltage is proportional to the output voltage by the transformer coupling, the over-voltage of output is indirectly detected using V_{DD} voltage. The OVP is triggered when V_{DD} voltage reaches 24 V. Debounce time (typically 105 μ s) is applied to prevent false triggering by switching noise.

Two-Level UVLO

Since all the protections of the GF001H are auto-restart, the power supply repeats shutdown and restart until the fault condition is removed. GF001H has two-level UVLO, which is enabled when protection is triggered, to delay the re-startup by slowing down the discharge of V_{DD} . This effectively reduces the input power of the power supply during the fault condition, minimizing the voltage/current stress of the switching devices. Figure 26 shows the normal UVLO operation and two-step UVLO operation. When V_{DD} drops to 6 V without triggering the protection, PWM stops switching and V_{DD}

is charged up by the HV startup circuit. Meanwhile, when the protection is triggered, GF001H has a different V_{DD} discharge profile. Once the protection is triggered, the IC stops switching and V_{DD} drops. When V_{DD} drops to 9 V, the operating current becomes very small and V_{DD} is slowly discharged. When V_{DD} is naturally discharged down to 6 V, the protection is reset and V_{DD} is charged up by the HV startup circuit. Once V_{DD} reaches 12 V, the IC resumes switching operation.

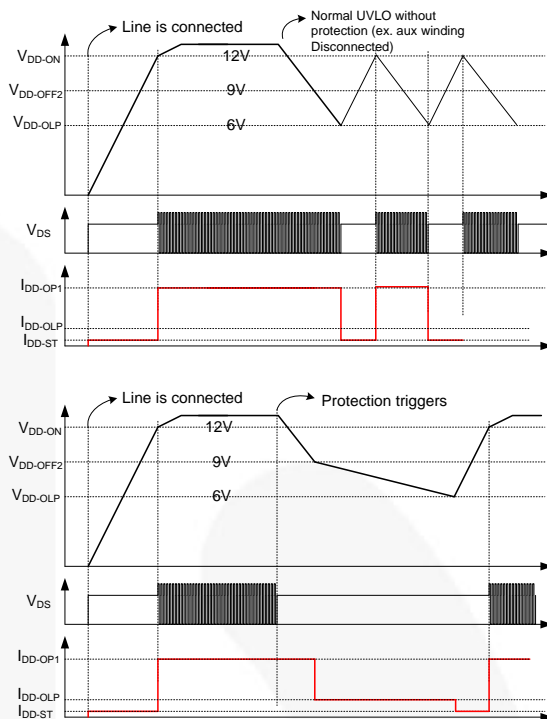
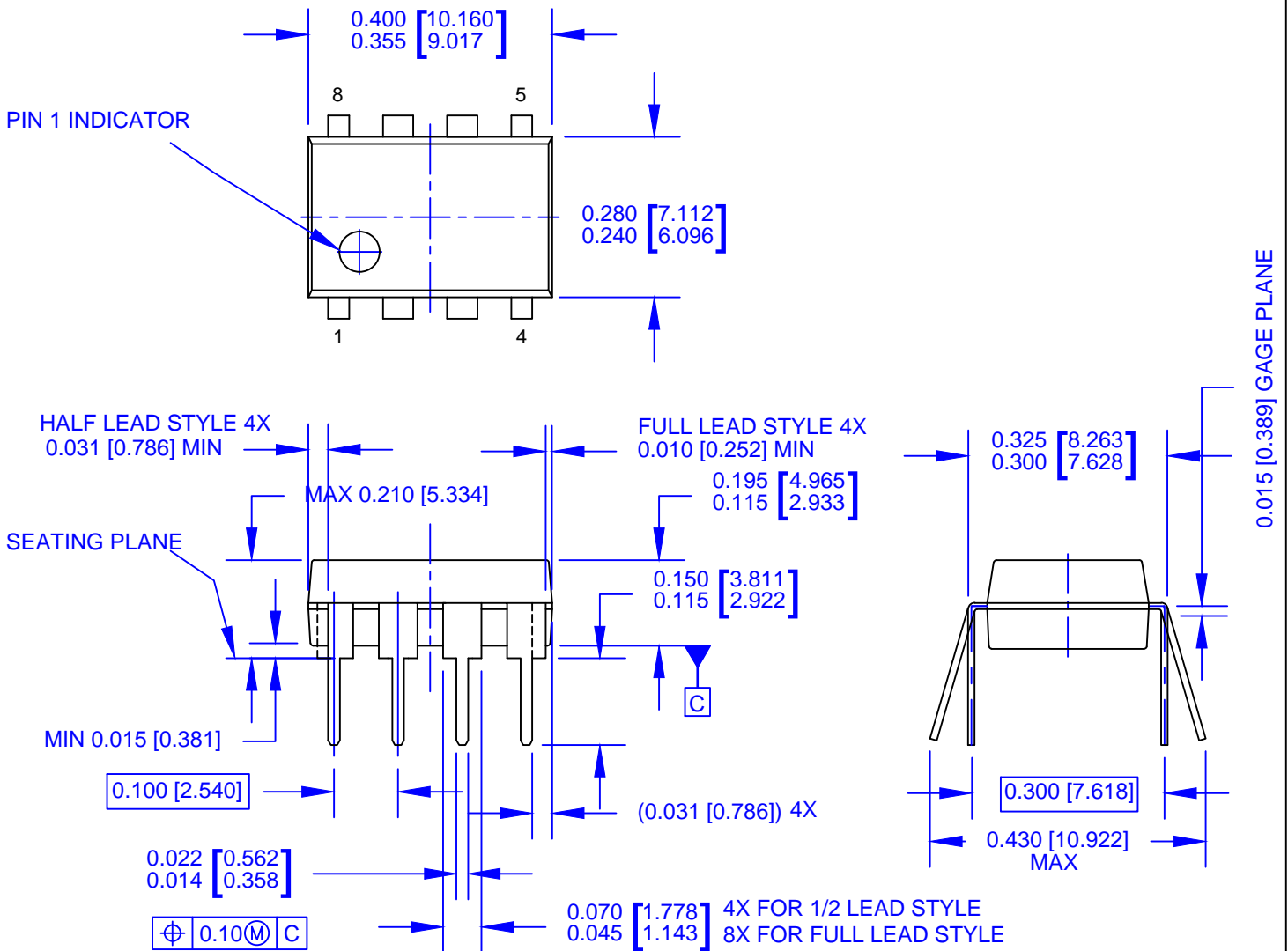

Figure 26. Two-Level UVLO



NOTES:

- A) THIS PACKAGE CONFORMS TO JEDEC MS-001 VARIATION BA WHICH DEFINES 2 VERSIONS OF THE PACKAGE TERMINAL STYLE WHICH ARE SHOWN HERE.
- B) CONTROLLING DIMS ARE IN INCHES
- C) DIMENSIONS ARE EXCLUSIVE OF BURRS, MOLD FLASH, AND TIE BAR EXTRUSIONS.
- D) DIMENSIONS AND TOLERANCES PER ASME Y14.5M-2009
- E) DRAWING FILENAME AND REVISION: MKT-N08MREV2.





TRADEMARKS

The following includes registered and unregistered trademarks and service marks, owned by Fairchild Semiconductor and/or its global subsidiaries, and is not intended to be an exhaustive list of all such trademarks.

- | | | | |
|--------------------------|--|---------------------------------------|------------------|
| AccuPower™ | F-PFS™ | OPTOPLANAR® | SYSTEM GENERAL® |
| AttitudeEngine™ | FRFET® | Power Supply WebDesigner™ | TinyBoost® |
| Awinda® | Global Power Resource SM | PowerTrench® | TinyBuck® |
| AX-CAP®* | GreenBridge™ | PowerXS™ | TinyCalc™ |
| BitSiC™ | Green FPS™ | Programmable Active Droop™ | TinyLogic® |
| Build it Now™ | Green FPS™ e-Series™ | QFET® | TINYOPTO™ |
| CorePLUS™ | Gmax™ | QS™ | TinyPower™ |
| CorePOWER™ | GTO™ | Quiet Series™ | TinyPWM™ |
| CROSSVOL™ | IntelliMAX™ | RapidConfigure™ | TinyWire™ |
| CTL™ | ISOPLANAR™ | Saving our world, 1mW/W/kW at a time™ | TranSiC™ |
| Current Transfer Logic™ | Making Small Speakers Sound Louder and Better™ | SignalWise™ | TriFault Detect™ |
| DEUXPEED® | MegaBuck™ | SmartMax™ | TRUECURRENT®* |
| Dual Cool™ | MICROCOUPLER™ | SMART START™ | μSerDes™ |
| EcoSPARK® | MicroFET™ | Solutions for Your Success™ | UHC® |
| EfficientMax™ | MicroPak™ | SPM® | Ultra FRFET™ |
| ESBC™ | MicroPak2™ | STEALTH™ | UniFET™ |
| F [®] | MillerDrive™ | SuperFET® | VCX™ |
| Fairchild® | MotionMax™ | SuperSOT™-3 | VisualMax™ |
| Fairchild Semiconductor® | MotionGrid® | SuperSOT™-6 | VoltagePlus™ |
| FACT Quiet Series™ | MTi® | SuperSOT™-8 | XST™ |
| FACT® | MTx® | SupreMOS® | Xsens™ |
| FastvCore™ | MVN® | SyncFET™ | 仙童® |
| FETBench™ | mWSaver® | Sync-Lock™ | |
| FPS™ | OptoHiT™ | | |
| | OPTOLOGIC® | | |

* Trademarks of System General Corporation, used under license by Fairchild Semiconductor.

DISCLAIMER

FAIRCHILD SEMICONDUCTOR RESERVES THE RIGHT TO MAKE CHANGES WITHOUT FURTHER NOTICE TO ANY PRODUCTS HEREIN TO IMPROVE RELIABILITY, FUNCTION, OR DESIGN. TO OBTAIN THE LATEST, MOST UP-TO-DATE DATASHEET AND PRODUCT INFORMATION, VISIT OUR WEBSITE AT [HTTP://WWW.FAIRCHILDSEMI.COM](http://www.fairchildsemi.com). FAIRCHILD DOES NOT ASSUME ANY LIABILITY ARISING OUT OF THE APPLICATION OR USE OF ANY PRODUCT OR CIRCUIT DESCRIBED HEREIN; NEITHER DOES IT CONVEY ANY LICENSE UNDER ITS PATENT RIGHTS, NOR THE RIGHTS OF OTHERS. THESE SPECIFICATIONS DO NOT EXPAND THE TERMS OF FAIRCHILD'S WORLDWIDE TERMS AND CONDITIONS, SPECIFICALLY THE WARRANTY THEREIN, WHICH COVERS THESE PRODUCTS.

AUTHORIZED USE

Unless otherwise specified in this data sheet, this product is a standard commercial product and is not intended for use in applications that require extraordinary levels of quality and reliability. This product may not be used in the following applications, unless specifically approved in writing by a Fairchild officer: (1) automotive or other transportation, (2) military/aerospace, (3) any safety critical application – including life critical medical equipment – where the failure of the Fairchild product reasonably would be expected to result in personal injury, death or property damage. Customer's use of this product is subject to agreement of this Authorized Use policy. In the event of an unauthorized use of Fairchild's product, Fairchild accepts no liability in the event of product failure. In other respects, this product shall be subject to Fairchild's Worldwide Terms and Conditions of Sale, unless a separate agreement has been signed by both Parties.

ANTI-COUNTERFEITING POLICY

Fairchild Semiconductor Corporation's Anti-Counterfeiting Policy. Fairchild's Anti-Counterfeiting Policy is also stated on our external website, www.fairchildsemi.com, under Terms of Use

Counterfeiting of semiconductor parts is a growing problem in the industry. All manufacturers of semiconductor products are experiencing counterfeiting of their parts. Customers who inadvertently purchase counterfeit parts experience many problems such as loss of brand reputation, substandard performance, failed applications, and increased cost of production and manufacturing delays. Fairchild is taking strong measures to protect ourselves and our customers from the proliferation of counterfeit parts. Fairchild strongly encourages customers to purchase Fairchild parts either directly from Fairchild or from Authorized Fairchild Distributors who are listed by country on our web page cited above. Products customers buy either from Fairchild directly or from Authorized Fairchild Distributors are genuine parts, have full traceability, meet Fairchild's quality standards for handling and storage and provide access to Fairchild's full range of up-to-date technical and product information. Fairchild and our Authorized Distributors will stand behind all warranties and will appropriately address any warranty issues that may arise. Fairchild will not provide any warranty coverage or other assistance for parts bought from Unauthorized Sources. Fairchild is committed to combat this global problem and encourage our customers to do their part in stopping this practice by buying direct or from authorized distributors.

PRODUCT STATUS DEFINITIONS

Definition of Terms

Datasheet Identification	Product Status	Definition
Advance Information	Formative / In Design	Datasheet contains the design specifications for product development. Specifications may change in any manner without notice.
Preliminary	First Production	Datasheet contains preliminary data; supplementary data will be published at a later date. Fairchild Semiconductor reserves the right to make changes at any time without notice to improve design.
No Identification Needed	Full Production	Datasheet contains final specifications. Fairchild Semiconductor reserves the right to make changes at any time without notice to improve the design.
Obsolete	Not In Production	Datasheet contains specifications on a product that is discontinued by Fairchild Semiconductor. The datasheet is for reference information only.

Mouser Electronics

Authorized Distributor

Click to View Pricing, Inventory, Delivery & Lifecycle Information:

[Fairchild Semiconductor:](#)

[GF001HN](#)